

Article provided to the Central Texas Airgun Club courtesy of:
[AirGunForum](http://www.airgunforum.net/) <http://www.airgunforum.net/>

WEIHRAUCH REKORD TRIGGER, OPERATION AND ADJUSTMENT

The Weihrauch Rekord trigger is a real two stage trigger (unlike in some other air guns). This means that the first, easy stage really is moving the sear. If this trigger is to be adjusted to a fine edge, **THE FIRST STAGE MUST BE SAFE**. Adjustment of this trigger to an easy single stage makes it dangerous! Don't start doing any adjustments until you have read through this whole procedure.

The best and safest way to adjust and see how the Rekord trigger works is to take it out of the gun as it can be cocked and fired outside of the gun. The gun should not be fired without a pellet.

Taking the trigger out of the gun is an easy thing to do. No special tools other than a 1/8" punch is required. **BUT *Read through the whole procedure and if you aren't comfortable doing this kind of work, don't start.***

To remove the stock, take out two screws in the forend and two in the trigger guard using good quality, preferably gunsmiths' screwdrivers. The gun mechanism should now slide out of the stock.

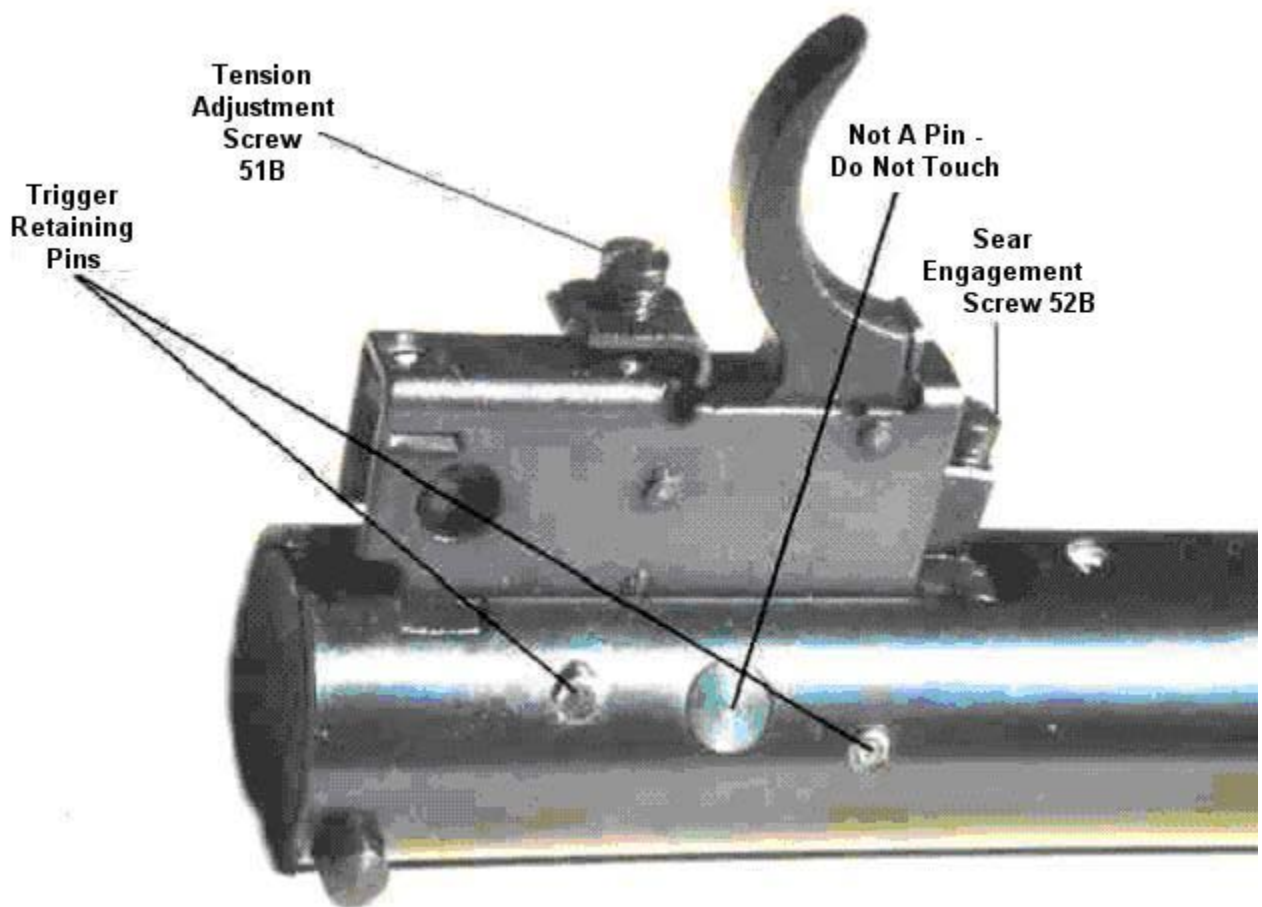

First, and most important, ensure the rifle is unloaded and not cocked.

Article provided to the **Central Texas Airgun Club** courtesy of:
AirGunForum <http://www.airgunforum.net/>

The trigger assembly is held in by the two small pins (about 1/8" in diameter) as illustrated. These need to be tapped out with a small punch of slightly smaller diameter. They shouldn't be excessively tight but if you tap from one side and they don't move, try from the other side. Drive the back pin out first, then rotate the trigger assembly about the front pin by pulling up on the back end and expect the safety pin and spring to pop out. If it doesn't, give it a gentle pull. Tap out the front pin and the trigger assembly can be lifted out. Keep the parts safe and note for reassembly that the front trigger pin is the longer.

The trigger can be cocked and fired outside the gun. Do this now and repeat 200 to 300 times for a new trigger, to smooth the mating surfaces within. Push the rear of the top lever (the one that hooks the piston on the other end) down into the trigger until it catches. Use a punch or screwdriver for this but take care not to scratch the parts. Once it locks in place pull the trigger and "fire" it.

Getting the trigger assembly back in the action is the reverse of getting it out, but it is easier if it is cocked before reassembly. Once re-inserted the trigger should be pulled prior to any attempt to cock the gun, so the sequence is:

- * cock the trigger.
- * slip the front of the trigger assembly in.
- * tilt down and tap in the front pin.
- * slip in the safety and hold it in while you lower the rear of the trigger assembly into place and tap in the rear pin.
- * pull the trigger.
- * check to see the gun can be cocked.

Note. Don't use an oversized punch for the trigger pins. Although the trigger unit is of high quality, if it is sloppy - ie. wobbles around when re-fitted, then it is probably unsafe and may require a replacement main cylinder.

Trigger Theory

The Rekord trigger assembly cannot be disassembled other than by a specialist, hence the **theory** of its operation. Sear polishing and surface smoothing is best achieved by 'working' the mechanism.

The Rekord is a four lever trigger. When it was designed, back in the 50's when it was considered a match trigger. Usually a trigger's perceived quality of operation increases with the number of levers present.

Article provided to the Central Texas Airgun Club courtesy of:
[AirGunForum](http://www.airgunforum.net/) <http://www.airgunforum.net/>

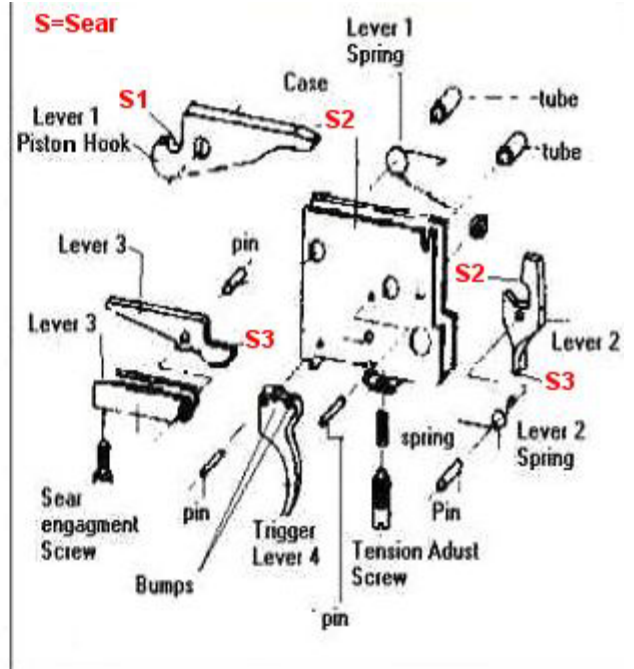
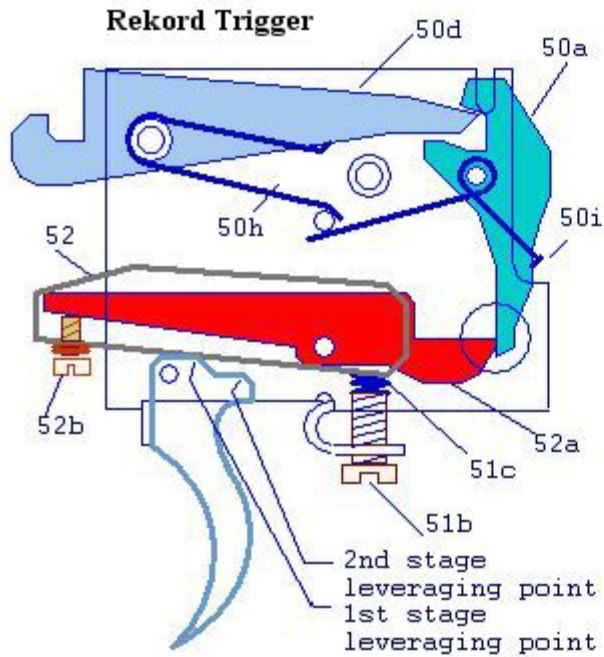

Caution:
Adjustment screws 51B and 52B on the coloured diagram should be secured with Loctite. It is vitally important that these screws are correctly adjusted and secured so they cannot move.

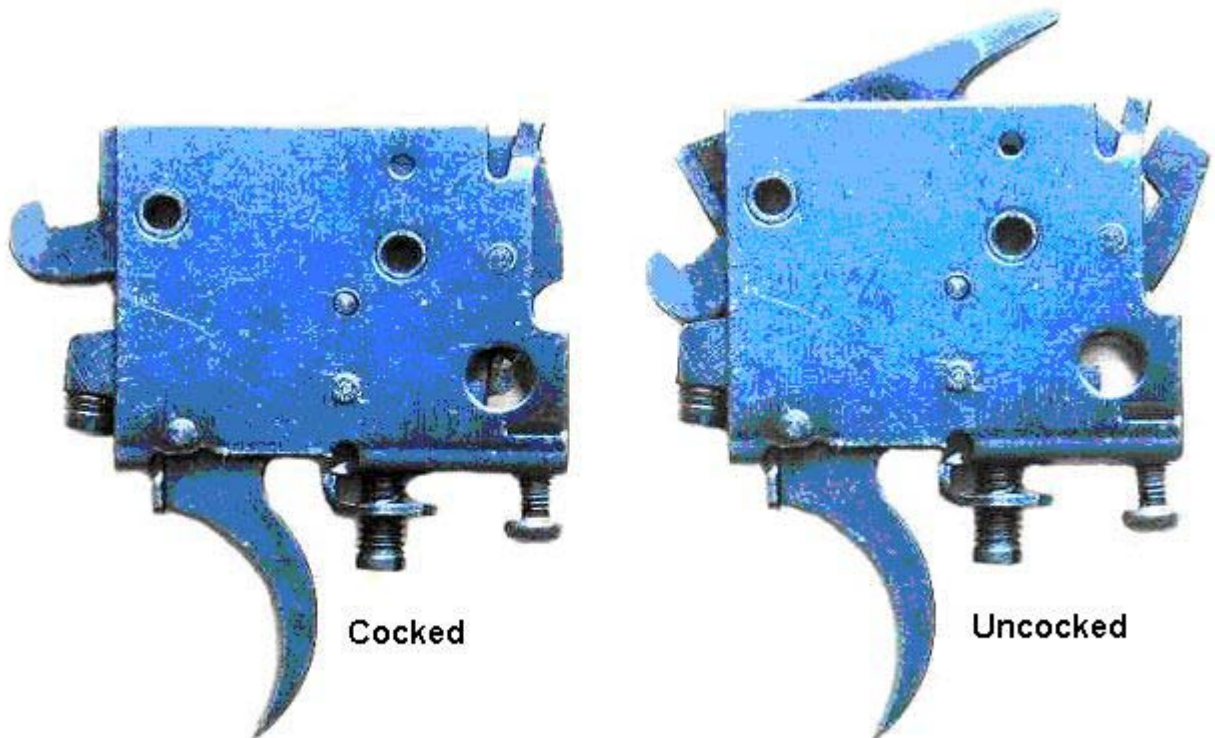

Article provided to the **Central Texas Airgun Club** courtesy of:
AirGunForum <http://www.airgunforum.net/>

Numbering starts at the point where the most force is, because the purpose of the first two levers and angles (at the sears) is to reduce force.

In order to understand triggers you need to understand two ancient machines: the incline plane and the lever.

Imagine an Egyptian trying to get a big stone block a couple hundred feet up the side of the pyramid. He uses an incline plane. The block (on rollers to reduce friction) is moved 1 foot up for every 20 feet along. If the block weighed 1,000lb. it would be pushing straight down with a force of 1,000lb., but it would only be pushing towards him (down the plane) with a force of about 50lb. (if there were no friction). This is what happens at the "Piston Hook" on lever No 1. The piston is trying to pull forward with a force of perhaps 400lb. There is a shallow angle where the piston and lever 1 are hooked together. This causes a force down on that end of lever 1 that is much less than 400lb. - say 9lb. (Engineers may note that the 400lb. of force is transferred to the frame by lever 1's pivot which is the forward bearing that has the front pin through it - ie. the front pin carries the load - good design.)

A lever is a solid piece with a pivot in it. When you press down on one end the other end rises. So if a pivot is in the middle of a lever, the downforce on one end will be equalled by the upforce at the other end. If the pivot is placed nearer the downforce end, the upforce would be reduced. This reduction depends on the ratio of the two distances to the pivot. Looking at lever 1, the measurements are: Hook to pivot pin = 0.5". Pivot pin to other tip of lever 1 = 1.625". This would change a 9 lbs downforce to 2.75 lbs. (Formula: the torques about the pivot have to be equal so $9 \times .5 = 2.75 \times 1.625$.) This means that the force necessary to control the release of that 400lb. mainspring is being reduced with each step. Lever 2 works exactly the same way reducing the force at sear 2 but since the pivot point is near the middle (about 0.5" each way) as a lever it just changes the direction of the force. By the time the force reaches sear 3 it is very small.

The first two levers have reduced the level of force to be controlled to a very low level probably on the order of ounces by the time it reaches sear No. 3, so what do the other two levers do? All mechanical triggers are effectively pulling one piece of metal out of the way of another to release a spring. This is usually called a "sear" and 3 sears are labelled on the drawing. There is only one that is "felt", sear No. 3, and that sets the timing of this trigger. The other two sears are tripped automatically when sear No. 3 is released. Since the amount of friction provided to lever 3 from lever 2 is relatively small, almost all the trigger feel comes from the adjustable spring and the mechanical leverage between the trigger (lever 4) and lever 3. This is the function of these two levers and is why, unusually, this trigger can be adjusted while out of the gun.

The trigger's force (lever 4) is what is felt as it presses on and moves lever 3. The first thing that the force on the trigger has to overcome is the friction on sear No. 3, which is known to be very small, together with the small friction of its moving parts PLUS the force that is applied by the spring that is compressed by the Tension Screw. So, the overall trigger pull force is set by adjusting the Tension Screw 51B. Don't set it below 14 ounces because there is some friction in the movement of the trigger, lever 3, and sear 3. Enough spring push is needed to ensure that if the trigger is pulled up to the second stage, consequently setting the sear on a knife edge and it is then relaxed, the sear resets to its safe position. The 14 ounce figure is probably a very safe one on a well lubricated trigger and with the trigger out of the

Article provided to the **Central Texas Airgun Club** courtesy of:
AirGunForum <http://www.airgunforum.net/>

gun this movement can be observed.

The trigger lever has two cams (bumps) on the surface where it contacts lever 3 and each is a different distance from the pivots of both the trigger and lever 3. When it switches from touching on the forward cam, which is a short distance from the trigger pivot but a longer distance from the pivot of lever 3, to the rear cam the force required by the trigger to move lever 3 against the spring increases. Also the leverage changes - with the light force the trigger moves a lot but lever 3 moves a little. With the heavier force the trigger moves a little and lever 3 moves much more. What is wanted is for that force increase to happen just before the sear 3 is about to release. As the trigger cannot be manufactured to wear-free and perfect tolerances these two adjustments are required for setting and maintenance.

The levers are shaped as they are so that the trigger can be cocked by pushing the piston pin into it. Lever spring 1 positions lever 1 down and out of the way of the piston pin and lever spring 2 positions lever 2 out of the way of the end of lever 1. When the piston runs into the face of lever 1 (which is above the pivot of lever 1) it forces lever 1 to rotate. The end of lever 1 rides on the face of lever 2 causing the top to rotate forward. When the bottom end of lever 2 slides off the end of lever 3 the sear sets and the whole thing becomes locked and cocked. The motion of lever 2 also lets the safety pop out to the safe position, which will block lever 2 until it is pushed in.

Making the Adjustments

Tools required for this step: A screwdriver and an Allen key to fit the two adjustment screws on the trigger.

The adjuster behind the trigger adjusts the tension on lever No 3 and since the trigger bears against lever No 3 it adjusts most of the force that the trigger has to overcome (the rest of the force being friction from the sear that is relatively small). It should be set to give a noticeable force on the trigger for the moment but should not be set too light. As it is accessible through the trigger guard, it can be adjusted at any time.

As the trigger assembly is cocked and fired, sear No. 3 can be seen working through the hole in the rear lower quarter of the trigger assembly. As slack (first stage) is taken up lever No. 3 should move. When the slack is released it should move back to where it started. This is the essential first stage safety. This tiny bit of sear engagement enables the trigger to be set to as fine a knife-edge as desired on the second stage and still have a safe trigger. The trigger should be pulled then a small dot of molybdenum disulphide lubricant should be put on the sear part of lever No. 3 where those two levers overlapped with a toothpick. These two levers are at right angles so no pressures are increased. This, together with 200 to 300 trigger firings performed earlier, should smooth out the sear motion to eliminate any effects of friction or grittiness in the trigger pull. Cock and pull the trigger a couple of more times to work in the Moly.

Adjustment of the screw in front of the trigger varies the amount of second stage sear engagement (turn clockwise looking down on it reduces the amount of engagement). Note that if this screw were to fall out, the gun would be perfectly safe as its removal results in a long, heavy second stage. This screw is usually stiff and quite difficult to turn so it tends to hold its adjustment. TINY adjustments should be

Article provided to the **Central Texas Airgun Club** courtesy of:

AirGunForum <http://www.airgunforum.net/>

made as sear engagement is reduced. The trigger should be cocked and pulled after each adjustment until sear engagement is as required. For safety, some second stage is essential, although it can be adjusted to very light pressure. Remember that if the gun is used for hunting, more second stage pressure is needed than for a pure target shooting environment.

Re-fit the trigger into the gun, re-fit the stock and trigger guard. The fine adjustments of the first stage pressure can now be made through the hole in the trigger guard, firing a pellet into a safe backstop each time.

Check to see that a sharp knock on the gun's butt will not cause it to fire.

Now you know how the trigger works and how to adjust it, it's easy to fine-tune it to allow for both wear and changes in taste.

Condensed from an original article published on the Beeman website.
April 2002.